

Item description/product images

**Description****Material:**

Carbon steel.

Version:

Forged, black electro zinc-plated.

Note:

We recommend using a lubricating paste to reduce wear to the adjustment screw. Risers are available to increase the height of the power clamp.

Supplied with clamping element, support element, DIN 508 slot key and grade 12.9 bolt.

Application:

The height of the clamping arm can be infinitely adjusted using the adjustment screw and the workpiece can then be clamped.

Advantages:

- Very high retaining forces of 22–49 kN.
- Low height.
- Simple element assembly.
- Enables very fast, simple clamping.
- Infinitely adjustable height and length.
- Use in 12-28 mm T-slots or M10, M12, M16, M20 grid systems.
- Thrust pad available in smooth and serrated versions.

Accessory:

Riser 04630

Thrust pads 04631

Drawings

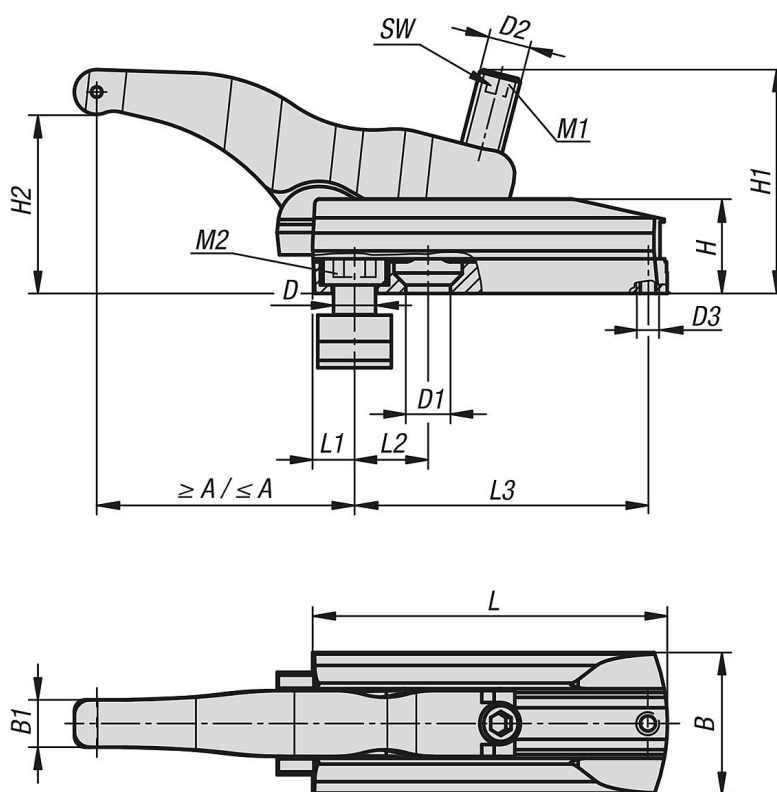

Overview of items

Order No.	Version 1	H2	A min.	A max.	B	B1	Slot width	D	D1	D2	D3	H	H1	L	L1	L2	L3	SW	Clamping force kN	Tightening torque M1 Nm	Tightening torque M2 Nm
04629-112135	long	6-68	13	110	54	18	14	M12	13	M16	M8	36	85	135	13	25	115	8	30	100	70
04629-116135	long	6-68	16	114	54	18	18	M16	17	M16	M8	36	85	135	16	28	115	8	30	100	150
04629-116155	long	5-80	16	134	60	20	18	M16	17	M20	M8	42	105	155	16	32	131	10	43	220	150
04629-120175	long	7-88	19	165	75	25	22	M20	21	M24	M10	52	125	175	19	36	146,5	12	49	220	200
04629-210065	short	5-38	15	50	45	13	12	M10	-	M12	M6	30	58	65	11	-	47,5	6	22	50	35
04629-212065	short	5-38	15	50	45	13	14	M12	-	M12	M6	30	58	65	11	-	47,5	6	22	50	40
04629-212095	short	6-50	12	82	54	18	14	M12	13	M16	M8	36	78	95	12	20	76	8	32	120	70
04629-216110	short	6-50	15	95	60	20	18	M16	17	M20	M8	42	92	110	15	26	87	10	40	150	150