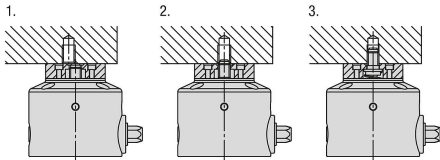

Item description/product images

**Description****Material:**

Carbon steel.

Version:

Body black oxidised.

Workpiece support tempered (HRC 39-45) and ground

Clamping screw hardened and black oxidised.

Note:

1. First, place the workpiece on the workpiece support or the clamping screw of the pull clamp. This will compress the internal spring and retract the clamping screw into the main body.

2. Position the tapped hole in the workpiece above the clamping screw. The tip of the clamping screw is pressed lightly into the tapped hole by the spring pressure.

3. When the drive element is actuated, the clamping screw rotates into the tapped hole of the workpiece and clamps it.

Advantages:

Automation capable

High clamping forces

Rapid clamping

Integrated clamping screw

Supplied with:

2x locating pins $\varnothing 8$ (h7) x 40.

1x protection plug.

Accessory:

04401-20 Extension unit.

Drawings

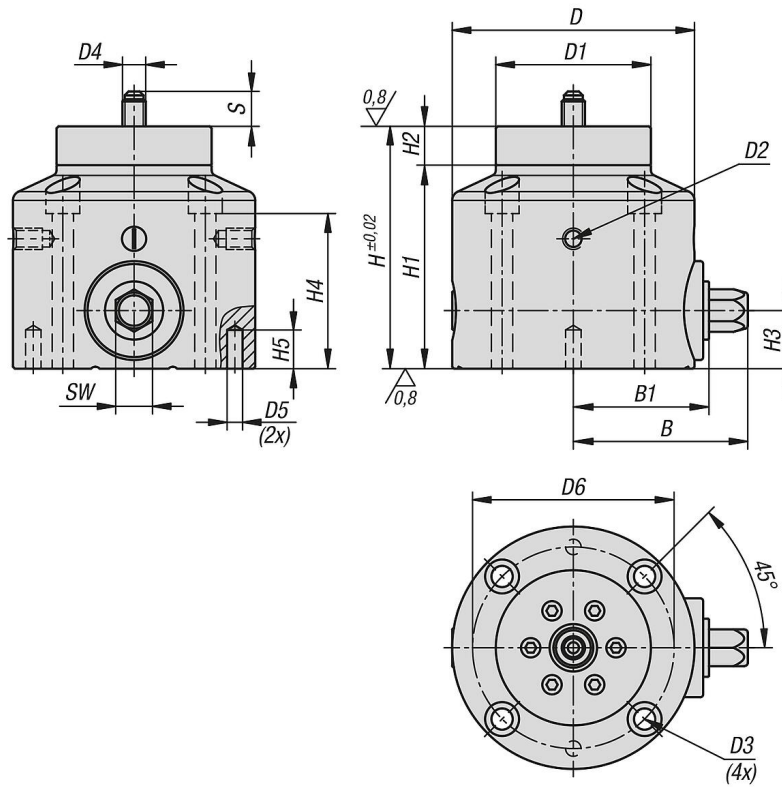

Overview of items

Order No.	B	B1	D	D1	D2	D3 for screw to DIN 912	D4	D5	D6	H	H1	H2	H3	H4	H5	Travel S	SW	Tightening torque max. Nm	Clamping force kN
04401-10-12	90	70	125	80	M10	M10	M12	8	104	125	105	20	30	80	20	18	19	27	10
04401-10-16	90	70	125	80	M10	M10	M16	8	104	125	105	20	30	80	20	21	19	45	15